



# Mr. Coffee®

# Mr. Coffee®

© 2020 Sunbeam Products, Inc. All rights reserved. Distributed by Sunbeam Products, Inc. Boca Raton, Florida 33431. Made in China.  
© 2020 Sunbeam Products, Inc. Todos los derechos reservados. Distribuido por Sunbeam Products, Inc. Boca Ratón, Florida, 33431. Fabricado en China.

**SIMPLY  
great  
COFFEE**

-  grab-a-cup auto pause
-  easy switch with power indicator



**SC05 SERIES**

5 Cup Coffeemaker

## USER MANUAL

# INTRODUCTION

Welcome and congratulations on the purchase of your new MR. COFFEE® CoffeeMaker. Your new SC05 Series CoffeeMaker will wake up with you in the morning and provide you tasty breaks during your hectic daily activities. How you enjoy your MR. COFFEE® CoffeeMaker is up to you! Our number one goal is to give you the best-tasting cup of coffee every time, so if you have any questions about your new coffeemaker, please contact us at 1-800-672-6333 or visit us at [www.mrcoffee.com](http://www.mrcoffee.com).



# IMPORTANT SAFEGUARDS

When using electrical appliances, basic safety precautions should always be followed to reduce the risk of fire, electric shock, and/or injury to persons including the following:

1. Read all instructions.
2. Do not touch hot surfaces. Use handles or knobs.
3. To protect against electric shock, do not place or immerse cord, plugs, or appliance in water or other liquid.
4. This appliance is not intended for use by children or by persons with reduced physical, sensory, or mental capabilities, or lack of experience and knowledge. Close supervision is necessary when any appliance is used near children. Children should be supervised to ensure that they do not play with the appliance. Keep the appliance and its cord out of reach of children.
5. Unplug from outlet when either the appliance or display clock (if provided) is not in use, and before cleaning. Allow to cool before putting on or taking off parts, and before cleaning the appliance.
6. Do not operate any appliance with a damaged cord or plug or after the appliance malfunctions, or has been damaged in any manner. Return appliance to an Authorized Service Center for examination, repair or adjustment. Do not attempt to replace or splice a damaged cord.
7. The use of an accessory not recommended by the appliance manufacturer for use with this appliance may result in fire, electric shock or injury to persons.
8. Do not use outdoors.
9. Do not let cord hang over edge of table or counter, or touch hot surfaces.
10. Do not place on or near a hot gas or electric burner, or in a heated oven.
11. Always attach plug to appliance first, then plug cord into the wall outlet (for appliances with detachable cords). To disconnect, turn any control to the off position, then remove plug from wall outlet.
12. Do not use appliance for other than intended use.
13. All lids should be closed during use.
14. Scalding may occur if the lid is removed or brew basket door is opened during or immediately after the brewing cycles. Contents may be hot. Allow to cool before opening the lid.

## For appliances with glass containers:

15. The container is designed for use with this appliance. It must never be used on a range top.
16. Do not set a hot container on a wet or cold surface.
17. Avoid sudden temperature changes, such as rinsing, washing, filling, or immersing a hot container with cold liquids.
18. Do not use a cracked or chipped container or a container having a loose or weakened handle.
19. Do not clean container with cleansers, steel wool pads, or other abrasive material.

For appliances with service panels:

20. **WARNING:** TO REDUCE THE RISK OF FIRE OR ELECTRIC SHOCK, DO NOT REMOVE THIS COVER. NO USER-SERVICEABLE PARTS INSIDE. REPAIR SHOULD BE DONE BY AUTHORIZED SERVICE PERSONNEL ONLY.

# SAVE THESE INSTRUCTIONS

## HOUSEHOLD USE ONLY



### POLARIZED PLUG

This appliance has a polarized plug, (one blade is wider than the other). As a safety feature to reduce the risk of electrical shock, this plug is intended to fit in a polarized outlet only one way. If the plug does not fit fully in the outlet, reverse the plug. If it still does not fit, contact a qualified electrician. Do not attempt to defeat this safety feature or modify the plug in any way. If the plug fits loosely into the AC outlet or if the AC outlet feels warm do not use that outlet.

## PRODUCT NOTICES

1. Place the appliance on a hard, flat, level surface to avoid interruption of airflow underneath the coffeemaker.
2. Glass decanters only: Discard the decanter immediately if it is ever boiled dry.
3. Glass decanters only: Protect the decanter from sharp blows, scratches or rough handling.
4. Do not operate the appliance with an empty water tank.
5. Keep the area above the appliance clear during use, as hot steam will escape the appliance.

## POWER CORD INSTRUCTIONS

A short power supply cord (or detachable power-supply cord) may be provided to reduce risks resulting from becoming entangled in or tripping over a longer cord. Longer detachable power-supply cords or extension cords are available and may be used if care is exercised in their use. If a long detachable power-supply cord or extension cord is used:

- a. The marked electrical rating of the detachable power-supply cord or extension cord should be at least as great as the electrical rating of the appliance;
- b. If the appliance is of the grounded type, the extension cord should be a grounding type 3-wire cord; and
- c. The longer cord should be arranged so that it will not drape over the counter top or table where it can be pulled on by children or tripped over unintentionally. Do not pull, twist or otherwise abuse the power cord.

Do not pull, twist or otherwise abuse the power cord.

# GET TO KNOW YOUR COFFEEMAKER

1. Brew Basket
2. Water Reservoir
3. On/Off Switch
4. Warming Plate
5. Carafe
6. Shower Head

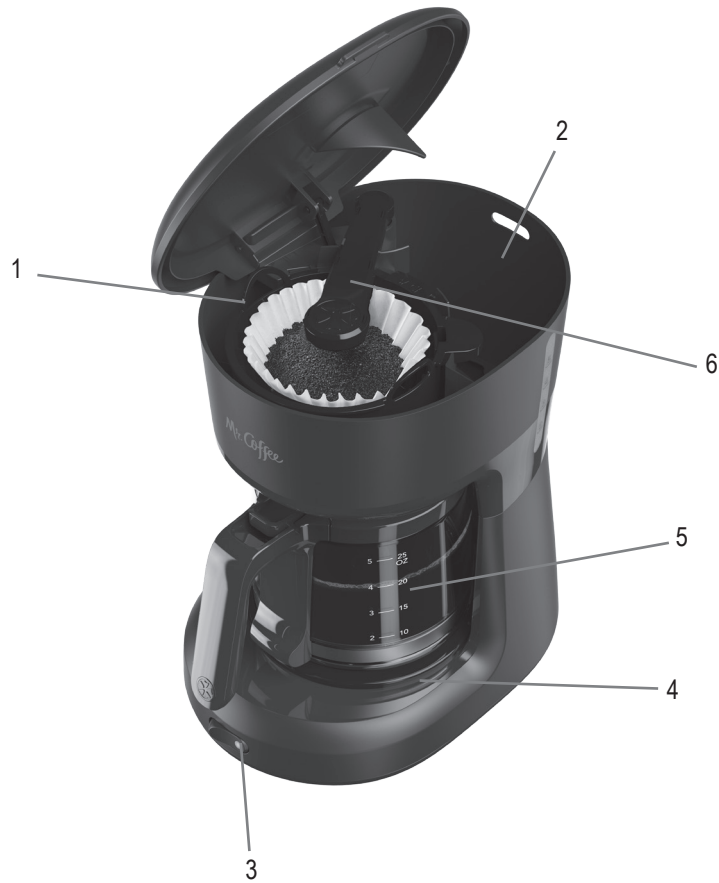

# GETTING STARTED

## Unpack your Coffeemaker

1. Unpack your coffeemaker and remove plastic bags, cartons and any tape on the unit.

**WARNING:** KEEP PLASTIC BAGS AWAY FROM CHILDREN.

## Clean Coffeemaker Before Use

Just follow these simple steps:

1. Wash the carafe lid and the brew basket in a mixture of mild detergent and water. Rinse each thoroughly.
2. Replace all the parts and close the lid. Then, run a brew cycle by adding only water to the coffeemaker. After adding water, switch the coffeemaker on.
3. When brewing is complete, turn your coffeemaker off. Turn your coffeemaker off by flipping the switch to the off position.
4. Discard the water in the carafe and rinse the carafe, carafe lid, and brew basket.

**NOTE:** Carafe, brew basket is top rack dishwasher safe. Water Filtration System is NOT!

# HOW TO MAKE YOUR FIRST POT OF COFFEE

## Suggested Coffee Measurement Chart:

To Brew	Ground Coffee	1 level tablespoon (tbsp) = 5 gr./0.17 oz. 1 cup = 5 fl. oz. of brewed coffee Use more or less coffee to suit your taste.
5 cups	6 tbs.	
2 cups	3 tbs.	

\*Using fine coffee or decaf may cause overflow.

Bonus: For a BOLDER CUP, use heaping TBS

1. Fill the carafe with fresh cold water to the desired level. 1 Mr. Coffee "cup" is equivalent to 5 fluid ounces. Pour into Water Reservoir.  
**NOTE:** Some water will be absorbed into the coffee grounds and water filter during the brewing process.
2. Insert and line the brew basket with a standard basket-style paper filter (sold separately) or reusable filter (if included).
3. Referencing the chart above, scoop the equivalent amount of coffee grounds into the filter using a tablespoon.
4. You are ready to switch your coffeemaker on.
5. Once finished using the coffeemaker please flip switch to off.
6. Enjoy consistently fresh coffee every time!

# WATER FILTRATION SYSTEM

The Mr. Coffee® carbon-based water filter (sold separately, unless included) helps remove up to 97% of the chlorine from the water and improves the taste of your coffee. To use the water filtration system in your Mr. Coffee® coffeemaker, please follow these steps:

1. Align the red indicator on the frame to the letter that corresponds with the month that you are using the disk for the first time. This serves to remind you to change the disk every month (approx. 50 brewing cycles). To change the disk, remove the used disk, insert new disk into the frame.  
**NOTE:** For optimum results, use the water filtration system with a permanent filter.
2. Rinse the water filter in fresh water before use.
3. Follow Adding Water and Coffee Instructions.
4. Position the filter on top of the brew basket, and brew according to your particular model's brewing instructions.
5. When you are done brewing your coffee, rinse the water filter with fresh water. Do not put your water filter in the dishwasher.

# HOW TO BREW THE PERFECT CUP

## Paper Filters vs. Reusable Filters

**PAPER FILTERS:** To achieve a smoother, less bitter cup of coffee, use a paper filter. It will be most effective in trapping bitter sediments.

**REUSABLE FILTERS:** For a more robust and full taste, use a reusable filter. It will allow the coffee's full flavor to fill your cup. Reusable filters have tiny holes that allow rich coffee oils to brew through.

# COFFEEMAKER EXTRAS

(not included with all models)



Reusable Filter

# HOW TO BREW THE PERFECT CUP CONT.

## Water

While it may not seem like an important ingredient, coffee is 98 percent water. The type of water that you brew with greatly affects the final taste. Always use clean, fresh water that is filtered and free of impurities - avoid soft water or well water. Please refer to the "Water Filtration" section to learn more about how your coffeemaker reduces impurities in water.

## Cleanliness

A clean coffeemaker is essential to brewing great tasting coffee each and every time.

## ROUTINE CLEANING

### Daily Cleaning

**CAUTION:** Make sure your coffeemaker is unplugged and has cooled completely before cleaning.

- Remove the brew basket, filter, carafe, carafe lid, and wash them in a solution of hot water and mild liquid soap, and dry thoroughly. You can also place in the dishwasher; top-rack only.

### Decalcifying your MR. COFFEE® SC05 Series Coffeemaker

Minerals (calcium/limestone) found in water will leave deposits in your coffeemaker and affect its performance. It's recommended that you regularly remove these deposits using vinegar.

1. **IMPORTANT:** Remove the water filtration system from the coffeemaker.
2. Prepare 4 cups or 20 fl. oz. / 592ml of undiluted, white household vinegar. Pour the vinegar into the water reservoir.
3. Place an empty 5 cup basket-style paper filter or MR. COFFEE® reusable filter into the brew basket and close the coffeemaker's lid.
4. Place the empty carafe back in the unit, centered on the warming plate.
5. Brew prepared cleaning solution through the coffeemaker.
6. Turn the coffeemaker off and let stand for 30 minutes.
7. Discard the cleaning solution and rinse the carafe thoroughly with clean water.
8. Fill the water reservoir with 5 cups of clean, fresh water.
9. Place the empty carafe back on the coffeemaker, centered on the warming plate.
10. Remove and discard the paper filter used during the cleaning cycle. If a MR. COFFEE® reusable filter was used during cleaning, remove it and rinse it thoroughly before replacing it in the brew basket.

11. Turn the switch to ON and allow the full brew cycle to complete, rinsing the coffeemaker with hot water.
12. Discard the water and rinse the carafe thoroughly with clean water.
13. Repeat steps 8 through 12 one more time, to ensure it is fully rinsed.

**Your coffeemaker is now clean and ready to brew the next pot of delicious, hot coffee!**

**NOTE:** It is recommended that you decalcify your coffeemaker every 30 days.

### Cleaning Frequency

TYPE OF WATER	CLEANING FREQUENCY
Soft Water	Every 80 Brew Cycles
Hard Water	Every 40 Brew Cycles

## CARAFE USE AND CARE

Follow the instructions below to reduce or eliminate the chance of breaking the glass carafe:

- Discard the carafe immediately if it is ever cracked.
- Protect the carafe from sharp blows, scratches or rough handling. Do not use harsh abrasive cleaners that may scratch the carafe. Scratches may cause the carafe to break.

## USER MAINTENANCE

This appliance has no user serviceable parts. Any servicing beyond that described in the Cleaning Section should be performed by an Authorized Service Representative only. See warranty available online.

## SERVICE MAINTENANCE AND WARRANTY

Service Maintenance and Warranty can be found online at [www.mrcoffee.com](http://www.mrcoffee.com) or call us toll-free at the Consumer Service Department, 1-800-MR COFFEE (1-800-672-6333).