



**READ BEFORE USE**  
**LIRE AVANT UTILISATION**  
**LEA ANTES DE USAR**

hamiltonbeach.com  
 For recipes, tips and product information.

hamiltonbeach.ca  
 Pour des recettes, des conseils et des renseignements sur le produit.

hamiltonbeach.com.mx  
 Para recetas, consejos, y información del producto.



**ENTER TO WIN \$100  
 TO SPEND ON WEBSITE**  
 Scan code or visit:  
[register.hamiltonbeach.com](http://register.hamiltonbeach.com)

**PARTICIPEZ POUR COURIR LA CHANCE DE  
 GAGNER UN MONTANT DE 100 \$  
 À DÉPENSER SUR NOTRE SITE WEB**

Balayez le code ou visitez le  
[register.hamiltonbeach.com](http://register.hamiltonbeach.com)

**INGRESE PARA TENER LA OPORTUNIDAD  
 DE GANAR \$100 PARA GASTAR EN  
 NUESTRO SITIO WEB**

Escanee el código o visite  
[register.hamiltonbeach.com](http://register.hamiltonbeach.com)

Open to US customers only • Ce concours  
 s'adresse aux clients des États-Unis seulement  
 • Este concurso está disponible sólo a clientes  
 de los Estados Unidos

# Hamilton Beach®



English .....	2
Français .....	13
Español.....	25



# IMPORTANT SAFEGUARDS

When using electrical appliances, basic safety precautions should always be followed to reduce the risk of fire, electric shock, and/or injury to persons, including the following:

1. Read all instructions.
2. This appliance is not intended for use by persons (including children) with reduced physical, sensory, or mental capabilities, or lack of experience and knowledge, unless they are closely supervised and instructed concerning use of the appliance by a person responsible for their safety.
3. Close supervision is necessary when any appliance is used by or near children. Cleaning and user maintenance shall not be made by children without supervision. Children should be supervised to ensure that they do not play with the appliance.
4. Do not touch hot surfaces. Use handles or knobs. Care must be taken, as burns can occur from touching hot parts or from spilled, hot liquid.
5. To protect against electric shock, do not place cord, plug, or coffee dispenser in water or other liquid.
6. Close supervision is necessary when any appliance is used by or near children.
7. Unplug from outlet when either the coffee dispenser or clock is not in use and before cleaning. Allow to cool before putting on or taking off parts and before cleaning the appliance.
8. Scalding may occur if the lid is lifted during the brewing cycle. Do not open lid until coffeemaker has cooled completely.
9. Coffee dispenser must be operated on a flat surface away from the edge of counter to prevent accidental tipping.
10. Do not operate any appliance with a damaged supply cord or plug, or after the appliance malfunctions or has been dropped or damaged in any manner. Supply cord replacement and repairs must be conducted by the manufacturer, its service agent, or similarly qualified persons in order to avoid a hazard. Contact Customer Service for information on examination, repair, or adjustment as set forth in the Limited Warranty.
11. The use of accessory attachments not recommended by the appliance manufacturer may cause injuries.
12. Do not use outdoors.
13. Do not let cord hang over edge of table or counter or touch hot surfaces, including stove.
14. The coffee tank is designed for use with this coffee dispenser. It must never be used on a range top or in a microwave oven.
15. Do not place coffee dispenser on or near a hot gas or electric burner or in a heated oven.
16. To disconnect coffee dispenser, turn controls to OFF and then remove plug from wall outlet. To unplug, grasp the plug and pull from the outlet. Never pull from the power cord.
17. **WARNING: Risk of Fire or Electric Shock.** Do not remove the bottom enclosure. No user serviceable parts inside. Repair should be done by authorized service personnel only.
18. Do not use appliance for other than intended use.
19. Keep-Warm plate may remain hot after the coffee maker is turned off.
20. Do not place coffee maker in a cabinet when in use.

## SAVE THESE INSTRUCTIONS!

# IMPORTANT

Never use coffee tank to pour hot coffee or carry hot coffee.  
Handle coffee tank when it holds only cold water or iced coffee.

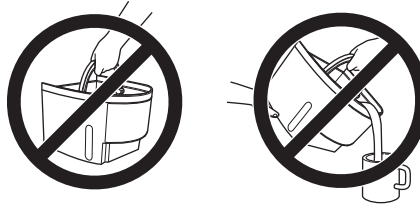

## Additional Information

- If overflow occurs: Let unit, coffee, and grounds cool completely before attempting any cleanup.
- Use only brand-name, high-quality filters.
- Use only 1 tablespoon of ground coffee for each cup of water. When making iced coffee, use 2 tablespoons of ground coffee for each cup of water.
- Use coffeemaker cleaner to prevent hard water deposits that affect coffeemaker performance. Clean monthly.
- Do not clean coffee tank in dishwasher.
- Read instructions before using.

## Other Consumer Safety Information

**This appliance is intended for household use only.**

**⚠ WARNING Electrical Shock Hazard:** This appliance has a polarized plug (one wide blade) that reduces the risk of electric shock. The plug fits only one way into a polarized outlet. Do not defeat the safety purpose of the plug by modifying the plug in any way or by using an adapter. If the plug does not fit fully into the outlet, reverse the plug. If it still does not fit, have an electrician replace the outlet.

The length of the cord used on this appliance was selected to reduce the hazards of becoming tangled in or tripping over a longer cord. If a longer cord is necessary, an approved extension cord may be used. The electrical rating of the extension cord must be equal to or greater than the rating of the appliance. Care must be taken to arrange the extension cord so that it will not drape over the countertop or tabletop where it can be pulled on by children or accidentally tripped over.

To avoid an electrical circuit overload, do not use another high-wattage appliance on the same circuit with your coffee dispenser.

# Parts and Features

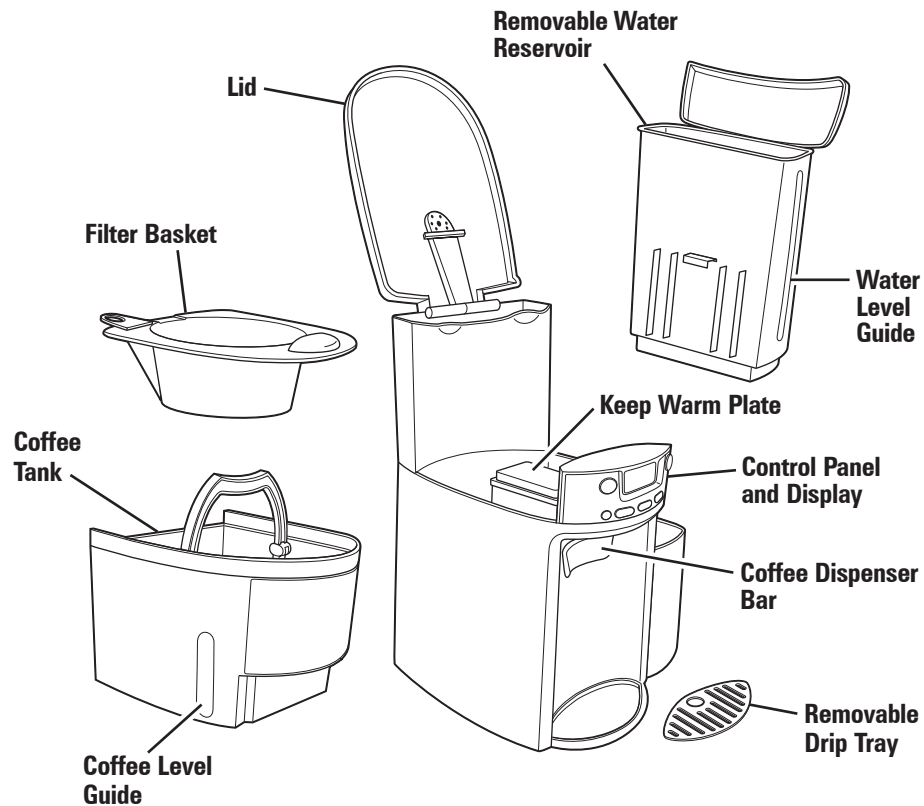

## Optional Accessories



**Water Filter**

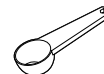

**Coffee Scoop**

To Order Accessories visit:  
[hamiltonbeach.com](http://hamiltonbeach.com)  
[hamiltonbeach.ca](http://hamiltonbeach.ca)

# How To Make Coffee

*\*Coffee scoop is optional feature on select models.*

**BEFORE FIRST USE:** Wash coffee tank, filter basket, and drip tray in hot, soapy water. NEVER put the coffee tank in dishwasher.

Coffee dispenser can be programmed to automatically shut off in 0, 1, 2, 3, or 4 hours as desired. Default is 2 hours for automatic shutoff.

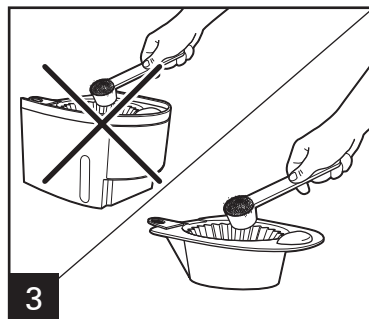
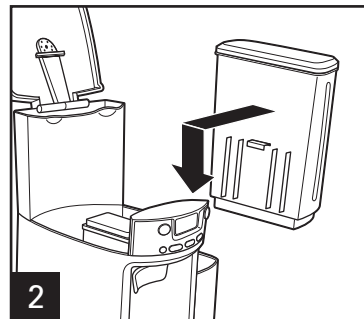
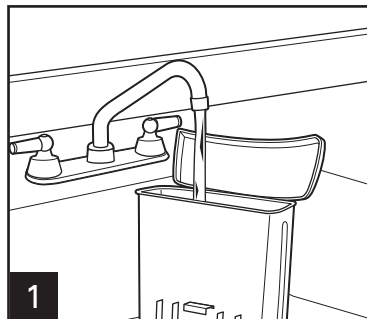

Place paper filter in brew basket; add coffee. Avoid getting coffee grounds in any other areas of the coffee dispenser.

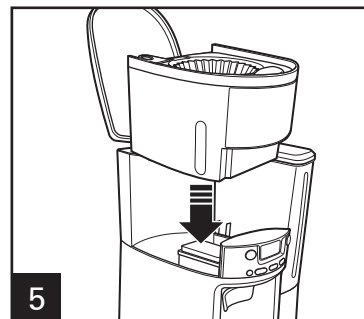
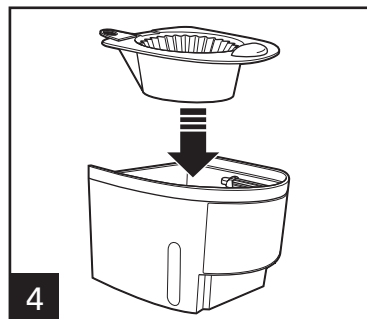

**Recommended Coffee Per Cup:**  
1 scoop\* or 1 level tablespoon per cup

**For Iced Coffee:**  
2 scoops or 2 level tablespoons per cup

**Maximum Amount of Coffee for coffee dispenser:**  
12 tablespoons

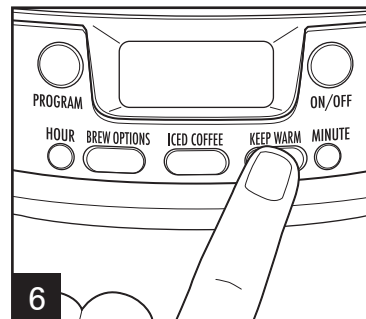

Set **KEEP WARM** hours to 0, 1, 2, 3, or 4.

## **⚠ WARNING** Burn Hazard.

- Never use coffee tank to pour or carry hot coffee.
- Handle coffee tank only when filling with ice for iced coffee and to clean tank after coffee dispenser has been shut off and the coffee is cool.
- If coffee dispenser overflows, unplug unit. Allow unit, coffee, and grounds to cool before cleaning unit, coffee, or grounds.

# How To Make Coffee (cont.)

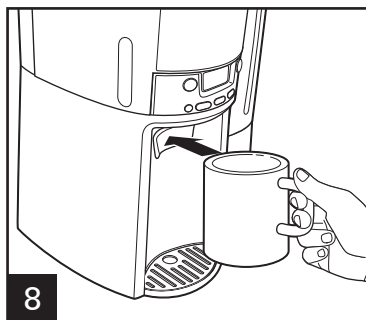
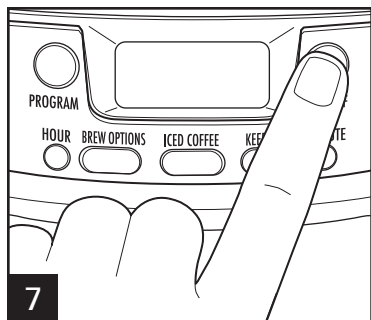

## Brew Options

### REGULAR

Press Brew Options button, no display

### BOLD

Enhanced full/strong-flavored coffee: Press **BREW OPTIONS** button until **BOLD** is displayed

### 1-4 CUPS

When brewing 1–4 cups of coffee: Press **BREW OPTIONS** button until **1-4 CUPS** is displayed

**NOTE:** **BOLD** mode will require additional time to complete a brewing cycle. It is recommended to select a Brew Option before pressing the **ON** button. However, the setting can be changed during the brewing cycle. If a Brew Option is not selected, the coffeemaker will automatically brew on the regular/default setting.

**TO REHEAT COFFEE:** Press and hold **ON/OFF** button for 3 seconds. This will reset the timer and keep coffee warm for selected number of hours (0, 1, 2, 3, or 4).

# To Make Iced Coffee

\*Coffee scoop is optional feature on select models.

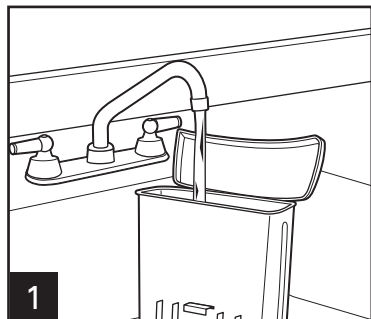

Fill removable water reservoir with water. Do not fill beyond the 6-cup line when making iced coffee.

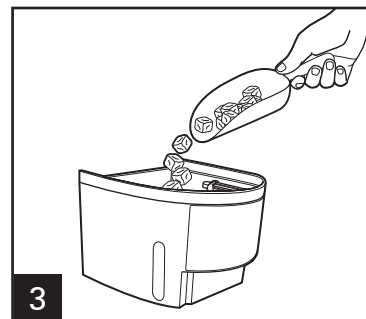
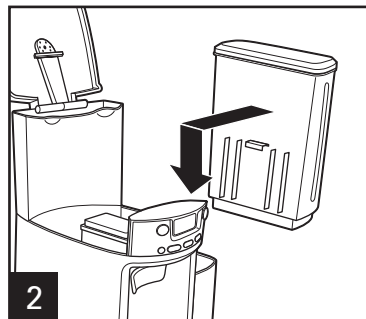

Fill coffee tank with ice to the **10 CUP** marking line.

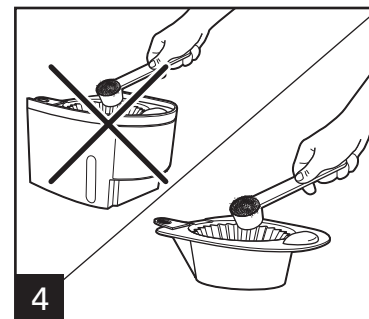

Place paper filter in brew basket. Brew double-strength coffee for iced coffee. Add 2 scoops\* or 2 level tablespoons of ground coffee per cup (up to 12 scoops).

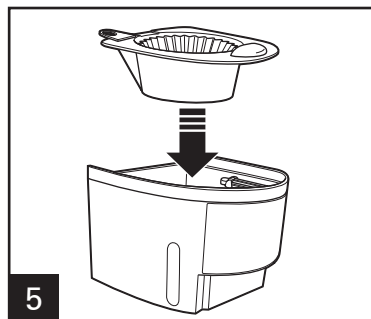

Make sure filter basket does not touch ice. If basket touches ice, tank is too full. Reduce ice to 10-cup marking line.

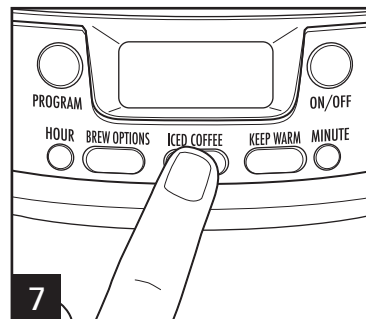
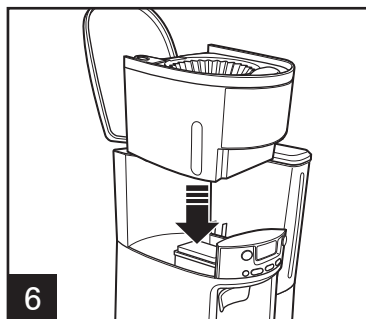

Select **ICED COFFEE**. Press **ON**. Keep Warm setting defaults to 0.

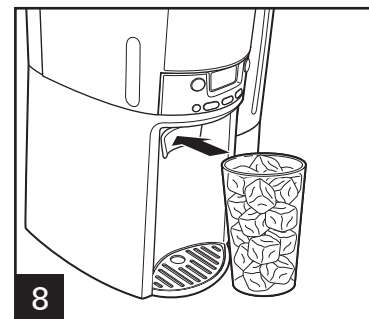

# Programming

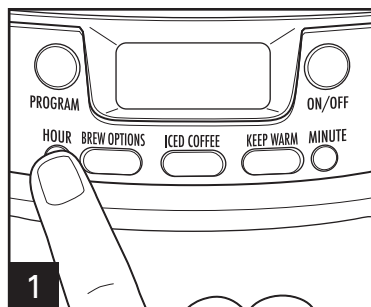

To set clock: Press **HOUR** and then **MINUTE**. **NOTE:** Clock time must be set for programming function to work.

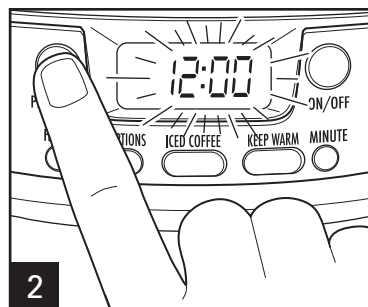

To program auto brew: Press and hold **PROGRAM** until clock flashes. Continue holding **PROGRAM**; then press **HOUR** and **MINUTE** until the desired brewing start time is reached. "START TIME" will display after time is selected. Select **BREW OPTIONS** and **KEEP WARM** settings, if desired.

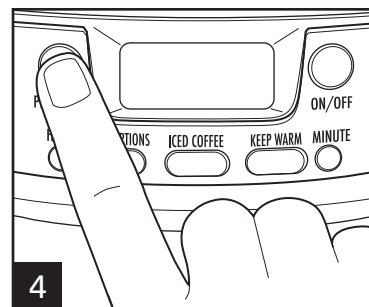
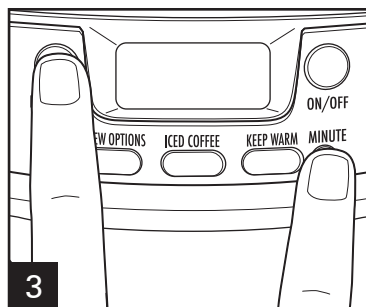

Press and release **PROGRAM** to activate automatic brewing. A green light will signal that the unit is in program mode. "START TIME" will disappear in the display after **PROGRAM** button is pressed.

## Iced Coffee Recipe

### Mocha Cinnamon Iced Coffee

- |                              |                       |
|------------------------------|-----------------------|
| 12 tablespoons ground coffee | 1 cup chocolate syrup |
| 1/2 teaspoon ground cinnamon | 8 cups ice cubes      |
| 1 1/2 cups half-and-half     |                       |

1. Fill water reservoir with water to the 6-cup line. Fill coffee tank with ice cubes to the 10-cup marking line. Place over water reservoir.
2. Place filter basket over coffee tank. Add coffee filter, coffee, and cinnamon to basket. Brew coffee.
3. For one serving, dispense 8 ounces of brewed coffee into a 12-ounce thermal cup or glass. Add 3 tablespoons half-and-half, 2 tablespoons chocolate syrup, and 1 cup ice. Stir and enjoy. **Servings: 8 (12-ounce)**



# General Cleaning Instructions

**⚠ WARNING**

**Shock Hazard.** Do not immerse cord, plug, or coffeemaker in any liquid.

## INSIDE OF COFFEEMAKER:

Follow steps 1–5 in “Cleaning With Vinegar.”

## WATER FILTER:

Remove the water filter from the water reservoir and wash by hand with warm, soapy water.

## COFFEE TANK FILTER SCREEN:

The coffee tank filter screen cannot be removed. To clean, run water through the top and bottom of the tank. Check for leaks.

## OUTSIDE OF COFFEEMAKER:

Wipe outside with a soft cloth and warm, soapy water. Do not use abrasive cleaners, since they will scratch the finish of the product.

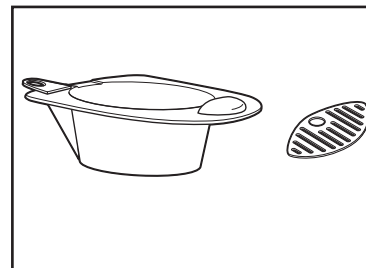

**DISHWASHER-SAFE**

DO NOT use the “SANI” setting when washing in the dishwasher. “SANI” cycle temperatures could damage your product.

## Water Filter (optional accessory)

For better tasting coffee, use a water filter.

Filter replacement is recommended every 60 cycles.

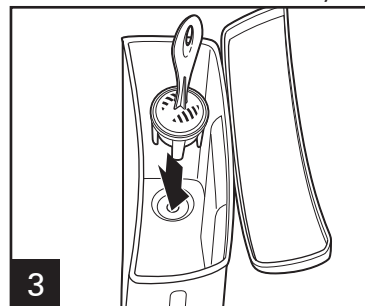
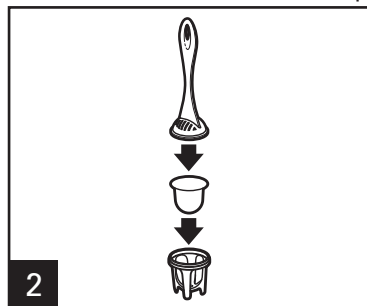
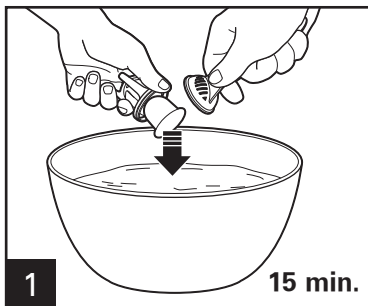

## Water Filter (Optional Accessory)

If using a water filter, it should be replaced every 60 cycles for best tasting coffee.

**To Order a Water Filter visit:**  
**hamiltonbeach.com**  
**hamiltonbeach.ca**

# Cleaning with Vinegar

Clean coffee dispenser at least once a month (once a week for areas with hard water).

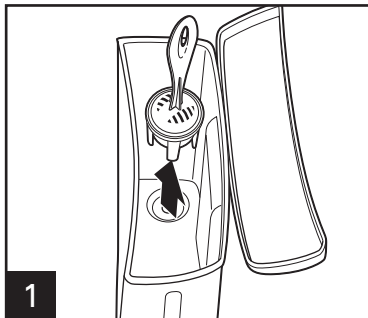

**1**  
Remove optional water filter.

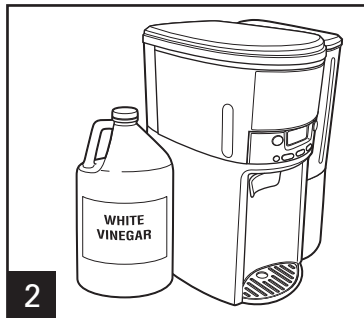

**2**  
Pour 1 pint (2 cups/500 ml) vinegar into water reservoir.

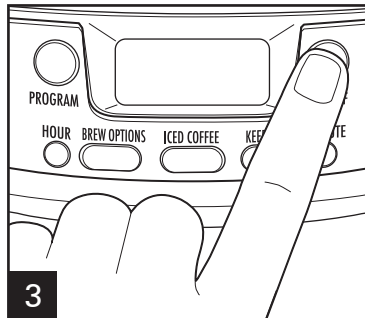

**3**  
Press **ON**. Turn **OFF** after 20 seconds and wait 30 minutes. Press **ON**. Turn **OFF** when finished. When cool, dispense several cups before emptying and rinsing reservoir. **NOTE:** Coffeemaker will remind you it is time for cleaning in two ways:

- Built-in cycle timer—Every 30 cycles, CLEAN will flash in display and stay illuminated for 2 cycles.
- Built-in residue sensor—CLEAN will appear in display when unit senses residue buildup and remain illuminated until the unit has been cleaned.

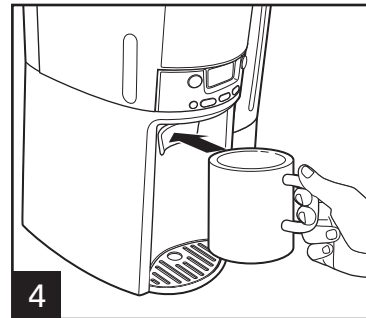

**4**

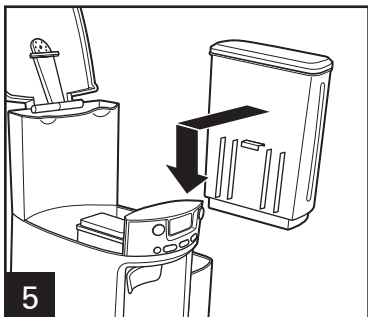

**5**  
Run 2–3 more brew cycles with **CLEAN WATER** only. Allow to cool between cycles.

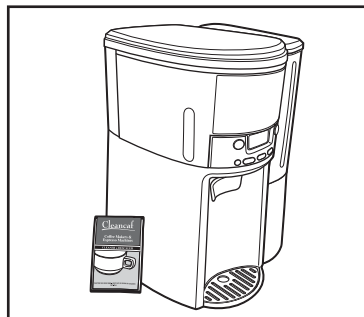

Coffeemaker cleaner is the recommended method for cleaning and is preferred over vinegar since it is more effective and leaves no odor. Follow package directions on coffeemaker cleaner. Dispense several cups before discarding solution.

**To Order Cleaner/Descaler visit:**  
[hamiltonbeach.com](http://hamiltonbeach.com)  
[hamiltonbeach.ca](http://hamiltonbeach.ca)

# Troubleshooting

PROBLEM	PROBABLE CAUSE
Coffee leaks from dispenser.	<ul style="list-style-type: none"><li>• Coffee grounds trapped in coffee tank dispensing mechanism under seal in coffee tank. See “Cleaning with Vinegar.”</li></ul>
“CLEAN” appears in display.	<ul style="list-style-type: none"><li>• This is a reminder to clean coffeemaker. See “Cleaning with Vinegar.”</li></ul>
Coffee tastes bad.	<ul style="list-style-type: none"><li>• Coffeemaker needs cleaning.</li><li>• Coffee ground too coarsely or too finely. Set coffee grinder to automatic drip grind.</li><li>• Coffee-to-water ratio unbalanced. Adjust for personal preference.</li><li>• Poor water quality. Use water filter or bottled water to make coffee. For iced coffee, too much ice in tank causing too long extraction time for grounds. Make sure ice is not above the 10-cup marking line.</li></ul>
Coffee not brewing or stops brewing/unit will not turn on.	<ul style="list-style-type: none"><li>• Mineral deposits have built up. Clean the coffeemaker following “Cleaning with Vinegar.”</li><li>• Water reservoir is empty.</li><li>• Unit is unplugged.</li><li>• Power outage or power surge. If surge, unplug; then plug back in.</li></ul>
Coffee brews slowly.	<ul style="list-style-type: none"><li>• <b>Coffeemaker needs cleaning.</b> Clean at least every 30 days to maintain proper performance.</li><li>• Coffeemaker is in the <b>1–4 CUPS</b> or <b>BOLD</b> modes. Press <b>BREW OPTIONS</b> button until no lights appear.</li></ul>
Coffee overflows basket.	<ul style="list-style-type: none"><li>• Excessive amounts of coffee grounds. See Table on page 5.</li><li>• Coffee ground too finely. Set coffee grinder to automatic drip grind.</li><li>• More than one paper filter in filter basket. Poor quality paper filter or wrong size paper filter.</li></ul>
Coffee is cold when dispensed (when not using ICED COFFEE setting).	<ul style="list-style-type: none"><li>• Selected Keep Warm hours have elapsed and coffeemaker has automatically shut off. See “To Reheat Coffee” instructions on page 6, or brew new cycle.</li></ul>

# Limited Warranty

This warranty applies to products purchased and used in the U.S. and Canada. This is the only express warranty for this product and is in lieu of any other warranty or condition.

This product is warranted to be free from defects in material and workmanship for a period of five (5) years from the date of original purchase in Canada and one (1) year from the date of original purchase in the U.S. During this period, your exclusive remedy is repair or replacement of this product or any component found to be defective, at our option; however, you are responsible for all costs associated with returning the product to us and our returning a product or component under this warranty to you. If the product or component is no longer available, we will replace with a similar one of equal or greater value.

This warranty does not cover glass, filters, wear from normal use, use not in conformity with the printed directions, or damage to the product resulting from accident, alteration, abuse, or misuse. This warranty extends only to the original consumer purchaser or gift recipient. Keep the original sales receipt, as proof of purchase is required to make a warranty claim. This warranty is void if the product is used for other than single-family household use or subjected to any voltage and waveform other than as specified on the rating label (e.g., 120V ~ 60 Hz).

We exclude all claims for special, incidental, and consequential damages caused by breach of express or implied warranty. All liability is limited to the amount of the purchase price. **Every implied warranty, including any statutory warranty or condition of merchantability or fitness for a particular purpose, is disclaimed except to the extent prohibited by law, in which case such warranty or condition is limited to the duration of this written warranty.** This warranty gives you specific legal rights. You may have other legal rights that vary depending on where you live. Some states or provinces do not allow limitations on implied warranties or special, incidental, or consequential damages, so the foregoing limitations may not apply to you.

To make a warranty claim, do not return this appliance to the store. Please write Hamilton Beach Brands, Inc., Customer Service Department, 4421 Waterfront Dr., Glen Allen, VA 23060, or visit [hamiltonbeach.com/customer-service](http://hamiltonbeach.com/customer-service) in the U.S. or [hamiltonbeach.ca/customer-service](http://hamiltonbeach.ca/customer-service) in Canada. For faster service, locate the model, type, and series numbers on your appliance.