

# AstroAI

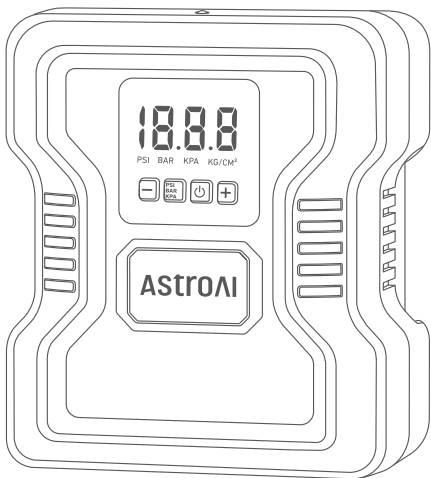

JY21P160-12

PORTABLE AIR COMPRESSOR

# USER MANUAL

EN

ES

DE

JP

FR

## CATALOGUE

English	-----	02 - 16
Deutsch	-----	17 - 31
Français	-----	32 - 46
Español	-----	47 - 61
日本語	-----	62 - 76

## INTRODUCTION

EN

Thank you for purchasing the AstroAI 160 PSI portable air compressor.

This product is a programmable air compressor with a LCD screen that is designed to monitor air pressure while inflating. Once the preset air pressure is reached, the Air Compressor will automatically shut off.

Thank you again for choosing AstroAI, if you have any questions or concerns regarding your product, please contact us via [support@astroai.com](mailto:support@astroai.com)

## WARNING

- Please read the instructions carefully before use. Incorrect usage may damage the product.
- Please practice electrical safety while using this product.
- Do not use the product for nonstandard purposes.
- Do not place the air compressor near any heat sources such as car exhaust pipes. Keep the device away from fire, corrosive gases, liquids, and strong magnetic fields. Do not use the product near any flammable liquids or gases.
- Do not disassemble the air compressor.
- Make sure the air compressor is intact before use, if it is damaged please do not use it.
- Do not use the air compressor if it is damaged or if its wires are exposed, doing so poses a risk of electric shock.
- Do not overinflate tires. Excessive pressure may cause injury and property damage.
- Do not aim the nozzle at people or any part of a human body. This product includes small accessories that are a choking hazard to children. Keep out of reach of children.

- Check the preset pressure value before use. The preset pressure value should match the object to be inflated.
- The air nozzle is compatible with all Schrader valves. It is appropriate to use with compact or midsize cars, SUVs, motorcycles, electric motorcycles and more. The air compressor is not intended for use with high-pressure or large-volume applications.
- Please do not use this product in the rain or where any liquids are present. Do not store the air compressor in high-temperature or humid environments.
- When not in use, disconnect the air compressor from all power sources.
- The air compressor may heat up during continuous use, please be careful during and after use.
- The maximum continuous use time is 15 minutes. Please let the pump cool for at least 10 minutes after every 15 minutes of use.
- PSI, BAR, KPA, KG/CM<sup>2</sup> are the pressure units, not the pressure levels.
- Do not use this product with 24V car power. Connect the air compressor to a 12V 15A DC cigarette lighter.
- Do not drag the product by pulling the power cord or the air hose.

- Do not use chemical cleaners to clean the air compressor. Only use mild soap and a cloth dipped in hot water to clean the plastic parts.
- If the attachments are missing or damaged after the package is delivered, please contact us.

## DIAGRAM

EN

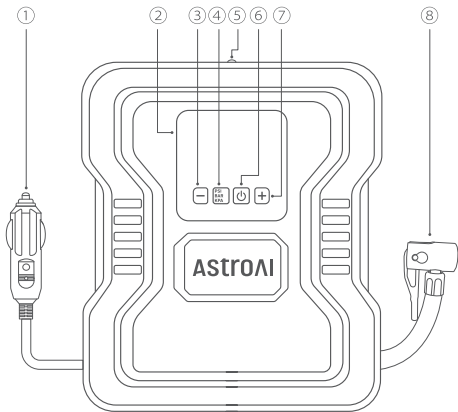

① 12V Cigarette Lighter Cable

② Screen

③ '-' Button

④ Unit Button

⑤ LED Light

⑥ Power Button

⑦ '+' Button

⑧ Quick Connector

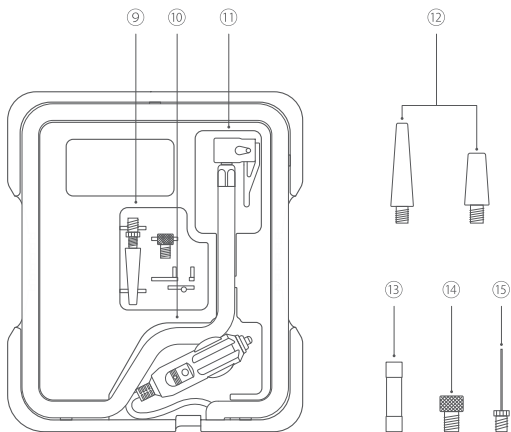

⑨ Accessory Compartment

⑬ Replacement Fuse

⑩ Power Cord Compartment

⑭ Presta to Schrader Adapter

⑪ Quick Connector  
Compartment

⑮ Needle Valve Adapter

⑫ 2X Air Nozzles



## FEATURES

EN

- Auto Shutoff: Once the preset air pressure is reached, the air compressor will automatically shut off.
- HD Digital Screen: Provides clear and accurate readings on an LCD screen. It is easy to operate, read and understand.
- Longer Power Cord: The 9.84ft (3m) cable enables it to easily reach any part of the car.
- Portable Design: Easy to carry and store in a car.
- Power Cut Memory Function: Automatically recalls the previously set pressure.

## INSTRUCTIONS

- Ensure that your car engine is running before you use the compressor.
- Remove the cigarette lighter and quick connector from the storage groove. Securely plug the cigarette lighter into your car's 12V outlet, the screen will light up when it is powered.

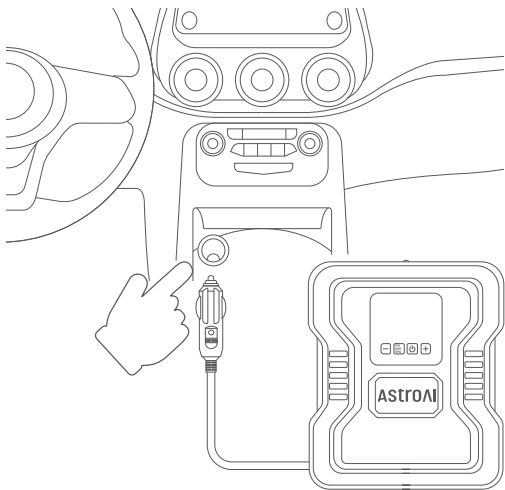

- Press the unit button to choose the desired unit.  
4 options: PSI, Bar, kPa, kg/cm<sup>2</sup>.

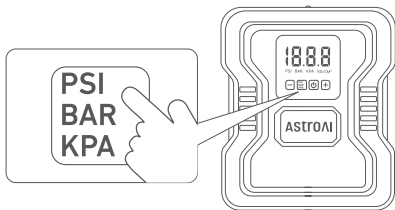

- Use the '+' and '-' buttons to set the desired pressure.  
Use the tire pressure guide on the inside of the driver's door for guidance. Make sure that the preset pressure is higher than the current pressure of your tire.

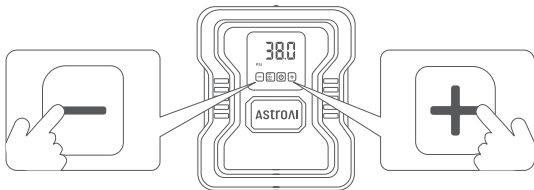

- Remove the valve cap from the valve stem of the tire and connect the air nozzle to the valve stem.

Tip: for better sealing when using the quick connector, align the valve stem, press it in firmly, and flip the small lever. Press and hold the Unit button to turn on the LED light.

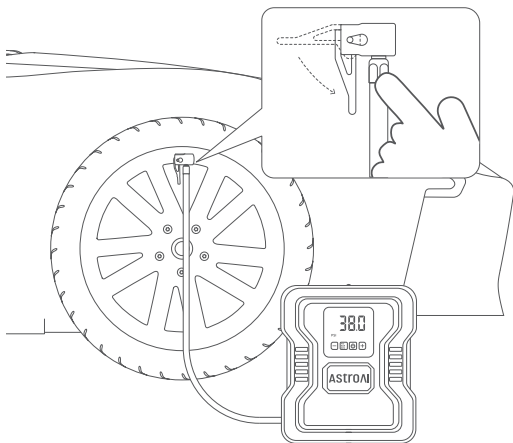

- Press the power button to start inflating. Do not touch the air hose during operation.

EN

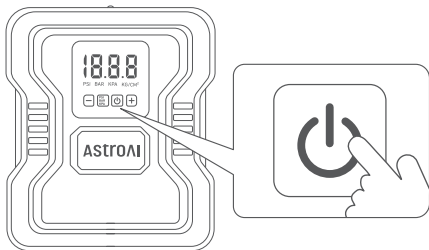

## TROUBLESHOOTING

### Air Compressor Is Operating Abnormally

- The inflation nozzle is not properly connected to the tire's valve stem.
- Ensure there is a strong connection between the power cord and 12V socket.
- The preset tire pressure is lower than the current tire pressure. Increase the preset tire pressure to the manufacturer recommended level.

## Air Compressor Will Not Inflate

- Ensure the in-line fuse is securely inserted correctly; replace the fuse if necessary.
- Check the vehicle's cigarette lighter fuse, it should be rated at 15A.
- Ensure there is a secure connection between the power cord and 12V socket.
- The preset tire pressure is lower than the current tire pressure. Increase the preset tire pressure to the manufacturer recommended level.

## Air Leaking Through The Hose

- Ensure there is a strong connection between the inflation nozzle and valve stem.

## Slow Inflation

- The inflation nozzle is not properly connected to the tire's valve stem.
- Excessive use will slow the inflation rate of the air compressor. Let it cool for 10 minutes.

## SPECIFICATIONS

EN

Model	JY21P160-12
Working Voltage	DC12V
Power Rating	120W
Inflating Speed	17L/Min
Maximum Working Pressure	160PSI
Display Units	PSI, BAR, KPA ,KG/CM <sup>2</sup>
Continuous Operation Time	15 Minutes
Inflation Hose Length	2.13ft (65cm)
DC Power Cord Length	9.84ft (3m)
Dimensions	5.78×6.69×3.11in (14.7×17×7.9cm)
Certificate	CE, FCC

## PACKAGE INCLUDES

AstroAI Portable Air Compressor	x 1
Air Nozzles	x 2
Needle Valve Adapter	x 1
Replacement Fuse	x 1
Presta to Schrader Adapter	x 1
User Manual	x 1

## RECYCLING

You may dispose of the product when its service life has ended. Please recycle the recyclable parts according to local guidelines.



## WARRANTY PERIOD

EN

### 2- Year Limited Warranty From AstroAI.

Each AstroAI Portable Air Compressor will be free from defects in material and workmanship. This warranty does not cover damage from neglect, misuse, contamination, alteration, accident, or abnormal conditions of operation or handling. This warranty covers the original purchaser only and is not transferable.

AstroAI always wants to provide our customers with excellent products and customer service.

Questions or Concerns? We're happy to help!

Please contact us via [support@astroai.com](mailto:support@astroai.com)